



mobile **AutoGRAPH**

VEHICLE & PERSONAL TRACKING SYSTEM

2015 VERSION
2.4
© TechnoKom

USER MANUAL



Table of Contents

Introduction	4
Version history	4
Software Copyright Notice	5
Safe Operation and Exposure to Electromagnetic Fields	6
Basic Information	8
Scope of Supply	8
Technical Specifications	9
Components of AutoGRAPH-Mobile	11
Getting Started	12
Installation of SIM-cards	12
Inserting the battery	13
Charging the battery	14
Switching on / off	14
AutoGRAPH-Mobile Functions	16
Coordinate acquisition	16
Data transmission	16
SMS	16
Alert signal	16
Tracker Indicators	18
Indication of GNSS receiver operation	18
Indication of GSM modem operation	18
Indication of the battery charging	18
Drivers Installation	19
Connection to PC	20
Care & Maintenance	20

Introduction

This User Manual applies to the AutoGRAPH-Mobile vehicle and personal tracking device (hereafter - tracker) produced by TechnoKom Ltd. It contains installation and connection procedures of the AutoGRAPH-Mobile, as well as its function and control.

This Manual constitutes the Operating Rules to be observed to ensure successful operation of the controller and its compliance with TU 6811-003-12606363-2013 and warranty provisions.

For proper operation of the AutoGRAPH-Mobile controller, a user should be aware of operating principles of the personal tracking system as a whole, as well as understand functions of its individual components. Therefore, it is recommended to study the fundamentals of operation of GPS navigation, GSM communication, peculiarities of short message service (SMS), GPRS and the Internet before starting.



Some functions of AutoGRAPH-Mobile controllers depend on capacities and configuration of the existing mobile network operator (MNO).

Furthermore, some functions may be disabled by the operator, or their operating range may be limited due to the settings of the network. To check availability of a certain function, contact your mobile network operator.



All information on functions, functional capabilities and other specifications related to AutoGRAPH-Mobile personal tracking controllers, as well as all information contained in this User Manual is based on current data (at time of writing) and is deemed to be valid as of the date of publication.

Technokom reserves the right to modify the information or specifications without prior notice or commitment.

Version history

This table provides a summary of the document revision.

Version	Description	Date
2.4	Version for the AutoGRAPH-Mobile device with extended battery capacity and SOS button.	03/2015

Software Copyright Notice

Products of TechnoKom referred to in this Manual may incorporate software stored in semiconductor memory or other media, copyrights to which belong to TechnoKom or third parties. Laws of the Russian Federation and other countries secure certain exclusive rights of TechnoKom and third parties to the software, which is subjected to copyright, for example, exclusive rights for distribution or reproduction.

Therefore, any alteration, reverse engineering, distribution or reproduction of any software incorporated in TechnoKom products, is prohibited to the extent provided by law. Furthermore, purchase of TechnoKom products does not imply direct, indirect or other granting of any licenses related to copyrights, patents and patent applications of TechnoKom or any third party, except for an ordinary, nonexclusive free license for use, which is granted in virtue of law upon each sale of the product.

Communication protocol between AutoGRAPH-Mobile vehicle and personal tracking controllers and a data server is considered to be confidential information and intellectual property of TechnoKom.

The communication protocol between AutoGRAPH-Mobile vehicle and personal tracking controllers and a communication data server shall be transferred by TechnoKom to integrators and software manufacturers only upon signing the Confidentiality Undertaking.

Unauthorized distribution of protocol used for communication between AutoGRAPH-Mobile vehicle and personal tracking controllers and communication data server is strictly prohibited.

Safe Operation and Exposure to Electromagnetic Fields

This section contains important information for effective and safe operation. Please read the information below before using AutoGRAPH-Mobile vehicle and personal tracking controllers.

Performance Characteristics

AutoGRAPH-Mobile vehicle and personal tracking controllers operate using a GSM/GPRS module and function as a low power receiver and transmitter. When the tracker is ON, it receives and transmits electromagnetic energy in the radiofrequency range. Operating band of the tracker ranges from 900 MHz to 1,990 MHz; the tracker uses digital modulation techniques.

When the tracker is in operation, a call service system controls the strength of sent-out RF signal.

Russian National Standards

AutoGRAPH-Mobile on-board vehicle tracking controllers are designed on the basis of TU 6811-003-12606363-2013 and comply with the following standards:

- GOST R MEK 60950-2009. Information Technology Equipment. Safety.
- GOST R 51318.22-2006. Electromagnetic Compatibility of Technical Equipment. Information Technology Equipment. Man-Made Radio Disturbance. Limits and Methods of Measurement.
- GOST R 51318.24-99. Electromagnetic Compatibility of Technical Equipment. Immunity of Information Technology Equipment. Requirements and Test Methods.
- GOST R Certificate of Conformity: GOST R № ROSS RU.MN11.H09267.
- TR CU Certificate of Conformity: TS RU D-RU.AL15.V.00712.

Exposure to Electromagnetic Fields

The design of the AutoGRAPH-Mobile vehicle and personal tracking controller complies with the following national and international standards, which specify the safe levels of exposure to radiofrequency electromagnetic fields:

- Ministry of Information Technologies and Communications of the Russian Federation. Regulations for application of user equipment (user radio stations) within GSM-900/1800 mobile telecommunication networks, approved under Order of Ministry of Information Technologies and Communications of the Russian Federation No. 114 dated September 20, 2005 (registered with Ministry of Justice of the Russian Federation on Sep. 28, 2005 under No. 7045).
- United States Federal Communications Commission, Code of Federal Regulations; 47 CFR part 2 sub-part J.
- American National Standards Institute (ANSI) / Institute of Electrical and Electronic Engineers (IEEE) C95.
- Institute of Electrical and Electronic Engineers (IEEE) C95 1-1999 Edition.
- National Council on Radiation Protection and Measurements (NCRP) of the United States, Report 86, 1986.
- International Commission on Non-Ionizing Radiation Protection (ICNIRP) 1998.
- National Radiological Protection Board of the United Kingdom 1995.
- Ministry of Health (Canada) Safety Code 6. Limits of Human Exposure to Radiofrequency Electromagnetic Fields in the Frequency Range from 3 kHz to 300 GHz, 1999.

- Australian Communications Authority Radiocommunications (Electromagnetic Radiation - Human Exposure) Standard 1999 (applicable to wireless phones only).

In order to ensure the best communication quality and compliance with the safety standards stipulated by the abovementioned documents, the equipment operating rules must be followed.

Electromagnetic Interference and Compatibility

Almost any electronic device is subjected to electromagnetic interference unless it is adequately shielded, has proper construction or is compatible with devices operating in another frequency band.

Prohibition on Use of Mobile Communication Devices

If you come across a signage or a notice, which prohibits the use of mobile communication devices, turn off your tracker. This is required to avoid electromagnetic interference with equipment sensitive to electromagnetic fields often used in hospitals, health care institutions or petrol stations.

Medical Devices

Cardiac Pacemakers

Medical Device Manufacturers Association advises to use mobile communication devices at distances greater than 15 cm from cardiac pacemaker so as to prevent the failure of the latter. These recommendations conform to the studies carried out by independent medical laboratories and Research Centre for Wireless Technologies.

Hearing Devices

Sometimes, use of mobile communication devices may cause troubles for wearers of certain hearing devices. In this case, consult the manufacturer of your hearing device to select another model.

Other Medical Devices

For other personal medical devices, contact your physician or device manufacturer to find out whether your device is adequately shielded from electromagnetic interference generated by mobile communication devices.

General Information on Safe Use

Explosion Hazard Zones

SWITCH OFF the tracker when entering the explosion hazard zone. Explosion hazard zones include: fuel stations, box girder decks on sea vessels, facilities or plants for handling and storage of fuels or chemicals, areas with chemicals or solid particles such as grains, dust or metal powder in atmosphere; and any other locations where it is usually required to shut off a vehicle's engine. Explosion hazard areas are often (yet not always) expressly marked.

Blasting Areas

In order to avoid interference with blasting operations, SWITCH OFF the device in blasting areas or in any locations marked with "Two-way radio-communication is prohibited" signage. Observe the signage instructions and rules.

Basic Information

The «AutoGRAPH-Mobile» (GLONASS/GPS) personal tracking controller is a portable autonomous electronic unit which tracks all movements of assets by recording the time and the route in the form of geographic coordinates received from the satellites of global navigation system GPS (NAVSTAR) or GLONASS.

In addition to coordinates, the tracker records a number of other parameters: speed, direction of movement, event counters, state of alert button, etc.

Collected data is transferred by a GSM 900/1800 mobile network operator by means of General Packet Radio Service (GPRS) to the dedicated server where it becomes available via the Internet for further analysis and processing by the AutoGRAPH Dispatch Software.

Scope of Supply

№	Description	Qty
1	AutoGRAPH-Mobile Personal Tracker (GLONASS+GPS)	1 pc.
2	Power Adapter+USB Cable	1 pc.
3	Warranty Certificate	1 pc.



①



②

Technical Specifications

Description	AutoGRAPH-Mobile
GPS/GLONASS Receiver	
Receiver type	uBlox MAX-M8Q
Supported GNSS	GPS + GLONASS / GALILEO / Beidou
Channels	72
Autonomous A-GNSS	Yes
Differential GPS (DGPS)	SBAS (WAAS, EGNOS, MSAS, GAGAN, QZSS), RTCM
Position accuracy when using GPS/GLONASS GNSS ¹ : <ul style="list-style-type: none"> • Horizontal (typ.), m • Velocity (typ.), m/s 	2.00 (50%) 0.05 (50%)
Time to first fix ¹ , s	26
Type of GPS/GLONASS antenna	Internal
GSM modem	
Communication	GSM / GPRS / SMS
SIM holders	2
Position accuracy when using LBS ² : <ul style="list-style-type: none"> • in city, m • in the countryside, km 	200...1000 1...30
Type of GSM antenna	Internal
General	
Connection to PC	USB 2.0
Internal FLASH memory, records	> 270.000
Alert button	Yes
Voice message service	Yes
Built-in accelerometer / motion sensor	Yes
Sleep mode when idling	Yes
Type of rechargeable battery	Li-Ion
Rated battery voltage, V	3.7
Battery capacity, mAh	1800
Charging time, min	approx. 160
External power supply voltage / Charging voltage, V	5
Operating temperature, °C	-20...+85

Description	AutoGRAPH-Mobile
Charging temperature, °C	0...+45
Dimensions, mm	92 x 58 x 22
Weight (with battery), g	90

¹ With nominal signals level -130 dBm.

² A wide specified range is supplied as the position accuracy when using LBS depends on base stations location around asset.

Components of AutoGRAPH-Mobile



1. GSM LED (orange).
2. GPS / GLONASS antenna placement.
3. NAVIGATION/CHARGING LED (bi-colour).
4. SOS button.

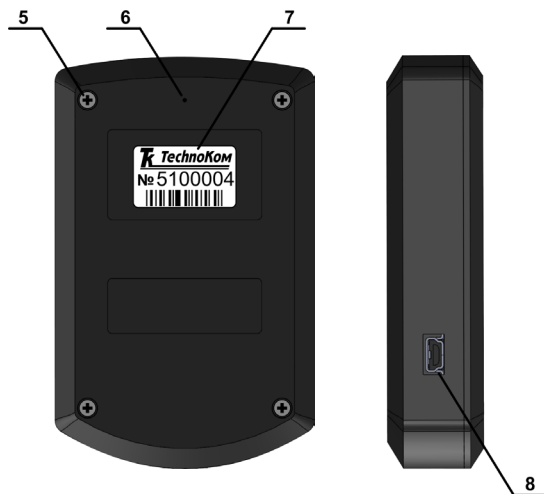

5. Fastening screw (x4).
6. POWER button (hidden).
7. Manufacturer's label.
8. Mini USB connector.

Getting Started

Before turning on the tracker, it is recommended to insert the SIM cards and charge the battery.

Installation of SIM-cards

The AutoGRAPH-Mobile is equipped with a dual SIM holder.

To install a SIM card:

- Unscrew the four fastening screws and remove the back cover of the tracker.

- Insert a SIM card into the lower retaining slot of the holder with the card's contacts facing the PCB (see fig.1). Be sure that the card's keying matches the key on the PCB.

- If necessary, insert a second SIM card in the upper retaining slot of the holder with the card's contacts facing downwards (see fig.3). Be sure that the card's keying matches the key on the PCB.

- When the SIM cards are inserted, replace the back cover and tighten the four fastening screws.

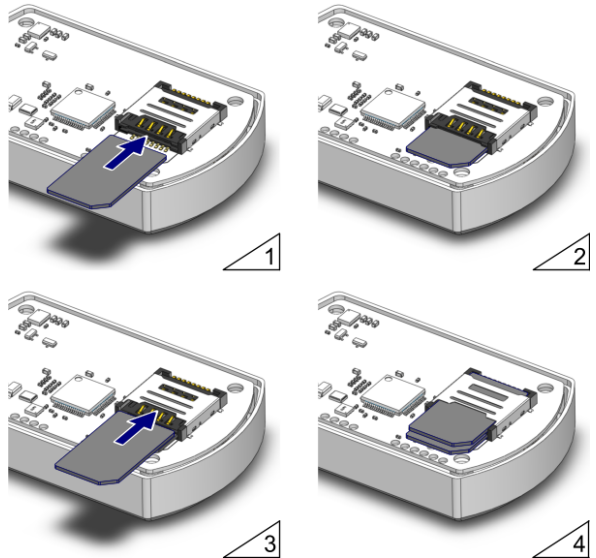

The SIM card installed in the lower retaining slot of the SIM holder is the main card. When switched on, the AutoGRAPH-Mobile will operate with this SIM card. The SIM card installed in the upper retaining slot of the SIM holder is the backup card. The tracker will switch to the backup SIM card, when the primary one is unavailable (disabled, damaged or not inserted). For proper operation it is quite sufficient to insert main SIM card in AutoGRAPH-Mobile. But the backup card provides the appropriate operation of the tracker even if the main SIM card is damaged. Due to this the tracker will stay connected and be able to transfer data.



Do a test of a new SIM card in a cell phone before you install it into the controller. This ensures that GPRS / SMS / USSD services are enabled and operate properly, the PIN code matches the code preset in the controller (in order to prevent locking), and the personal account associated with the SIM card has the sufficient balance for successful operation of the services.

Inserting the battery

The AutoGRAPH-Mobile comes with a rechargeable Li-Ion battery. The trackers are supplied with batteries of 1800 mAh capacity.

To insert the battery:

- Unscrew the four fastening screws and remove the back cover of the tracker.
- Remove the PCB from the case.
- Connect the battery to the Power connector located on the rear of the PCB (see fig.1).
- Insert the PCB back into the case.
- If necessary, turn on the tracker following the steps described in the “Switching on / off” section.
- Replace the back cover and tighten the four fastening screws (see fig.2).

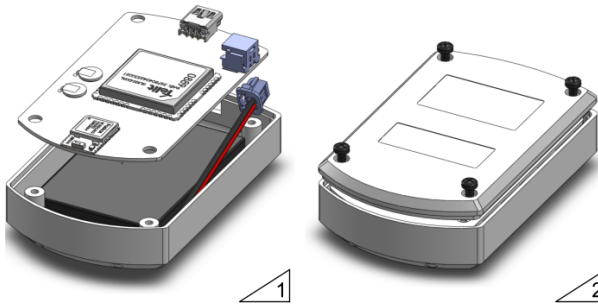

Before installation, check the battery for any damage. Do not use expired batteries. Use only the battery supplied with the tracker.



To prevent incorrect connection, which can damage the tracker's supply circuit with short-circuit current, the battery's connector (male) and the Power connector (female) on the PCB are keyed. Be sure that the battery's keying matches the key on the Power connector.

Charging the battery

Before turning on and starting use of the AutoGRAPH-Mobile, it is recommended to charge the battery.

The AutoGRAPH-Mobile comes with the USB power adapter and a USB cable (USB AM – USB miniB 5pin) for charging the battery from an electrical mains of 220 V or from a PC.

To charge using the USB power adapter:

1. Connect the small end of the USB cable to the USB-mini connector of the tracker.
2. Connect the other end of the USB cable to the power adapter.
3. Connect the power adapter to a power outlet. Charging will automatically start.

To charge using USB cable:

1. Connect the small end of the USB cable to the mini USB connector of the tracker.
2. Connect the other end of the USB cable to a PC. Be sure that the PC is turned on.
3. Charging will automatically start.

During the charging NAVIGATION / CHARGING LED simultaneously flashes green and red once a second. When the battery is charged the LED does not flash.

Average charging time is 160 minutes.



When connecting an external power to the tracker (using power adapter or USB cable), the tracker will automatically start its operation.

Switching on / off

When connecting the external power supply (using USB cable) the tracker automatically switches on. When connecting to the internal battery the tracker must be switched on by pressing the POWER button to start operation. Before switching on, be sure that the battery is charged.

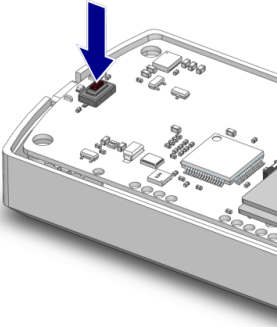

The POWER button is hidden in the tracker's case. To press it:

- Unscrew the four fastening screws, remove the back cover of the tracker and directly press the button;
- OR insert any pointed object (e.g. small bent paperclip) into the small hole above manufacture's label on the back cover.

Switching on

Before switching on, insert SIM cards into the tracker and connect the battery.

To switch the tracker on:

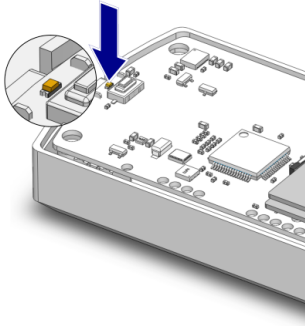

- Press the POWER button for a few seconds;
- As soon as the POWER LED turns on, release the button.
- The POWER LED is located above the POWER button. When the back cover is removed it is easy to see the LED flashing. If the back cover isn't removed, the LED can be seen through the hole intended for the access to the POWER button.
- Now the tracker is ready to operate.



The AutoGRAPH-Mobile can be set up to turn on only when the external power supply is connected (5V). This mode can be used when the tracker is installed in a vehicle and allows to preserve the battery power.

Switching off

To switch the tracker off:

- Press the POWER button for a few seconds;
- As soon as the POWER LED turns on, release the button and quickly press it again.
- The POWER LED is located above the POWER button. When the back cover is removed it is easy to see the LED flashing. If the back cover isn't removed, the LED can be seen through the hole intended for intended for the access to the POWER button.
- After the second press the tracker turns off.



When switching the tracker off, the second press must be performed while the POWER LED is ON (during about 3 seconds after the first press). Otherwise, the switch off procedure should be started again. It is made in order to suspend an accidental switching off of the tracker.

For proper operation the tracker must connect to a GSM network and acquire the position. For the first start, it can take up to 23 seconds to determine the coordinates. The tracker's operation is indicated with two LEDs. More detailed information on the indication is given in the "Tracker's Indication" section.

AutoGRAPH-Mobile Functions

Coordinate acquisition

In normal mode, the AutoGRAPH-Mobile acquires coordinates of the asset after the specified period and records the coordinates into FLASH memory. When turning on the tracker for the first time, it can take up to 26 seconds to acquire the position. The acquisition time depends on how clear the view of the sky is and for the best performance, it is recommended to locate the tracker with the GPS/GLONASS antenna facing the sky. It is not recommended to cover the tracker with a metallic object.

State of the GNSS receiver is indicated with the NAVIGATION/CHARGING LED (see the "Tracker's Indication" section). Depending on settings, the tracker can switch to Standby mode, when the asset is in an idle state. As soon as motion is detected, the tracker will return to normal mode of operation.

Data transmission

Collected tracking data is transferred to a preset server. The tracker must be covered by GSM network and GPRS must be available to transfer the data to the server. The state of the GSM modem is indicated with the GSM LED (see the "Tracker's Indication" section). When the GSM modem is OFF, the GSM LED does not flash. If a SIM card is not inserted or incorrect PIN is entered, the tracker switches the GSM modem off and data transmission is not available.

SMS

Incoming SMS

The AutoGRAPH-Mobile supports remote configuration. To configure the tracker remotely, you should send an SMS with a control command to the tracker, ensuring that the telephone number of the active SIM card is used. Advanced customers can send the settings via the data server.

Outgoing SMS

On request, the tracker sends the current coordinates to the customer by SMS. The coordinates are sent as a link to an online mapping service. By default, the tracker supports Yandex Maps, Yandex Satellite, Google Maps, and Google Satellite services, but the customer can specify any other format of the coordinates using the AGMobileConf Program.

Also the tracker can be set up to send a notification by SMS, when it enters / exits the geofenced area.

Alert signal

This option is designed for use in life threatening or other emergency situations.

The AutoGRAPH-Mobile is equipped with an SOS button and capable of sending an alert SMS with the current coordinates of the asset. In an emergency, press and hold the alert button for at least 3 seconds.

The AutoGRAPH-Mobile can be customized to perform the following actions, when the alert button is pressed:

To send SMS with the current coordinates

The tracker can be set up to send an SMS with asset's coordinates to preset telephone numbers. Up to 4 telephone numbers can be stored in the tracker's memory.

The tracker sends two alert SMS messages. The first message is short and contains time of alert activation and the current coordinates, if they are available. The second SMS contains the current coordinates and the last valid coordinates of the asset. The coordinates are sent as a link to an online mapping service.

The first (short) SMS is designed to be sent as one message to increase the reliability of data delivery. The second SMS is longer than the first one, therefore, it may be received as

multiple messages, which can cause data loss if one of the messages isn't delivered to the customer.

If coordinate acquisition is unavailable using the GNSS, the tracker will determine its approximate GSM localization. As soon as the coordinates are available, the device will send them to the customer.

To send data to a preset server

The tracker can be set up to transfer the collected data to a preset server before the next period of data transfer. Note, that in the alert mode the tracker transfers the data from internal memory in roaming even if the data transmission in roaming is disabled in the tracker's settings.

To make a voice call

The tracker can be set up to send a voice message to preset telephone numbers. The tracker will call to all preset numbers in sequence until one of the recipients answers the call. When answering the call, the recipient will hear a preset voice message.



The AutoGRAPH-Mobile remembers state of the SOS button even after the restart. If the tracker does not perform all preset functions of the SOS button before turning off, it will complete tasks after turning on.

Tracker Indicators

The AutoGRAPH-Mobile has two LEDs intended to indicate the device operation.

Install SIM cards, connect the battery and turn on the tracker. The tracker will be ready to operate after location acquisition and connecting to a GSM network.

Indication of GNSS receiver operation

Location data is not available – NAVIGATION / CHARGING LED (bi-colour) flashes green twice a second.

Searching for satellites – NAVIGATION / CHARGING LED flashes green once every second.

Location is acquired – NAVIGATION / CHARGING LED flashes green once every three seconds.

Indication of GSM modem operation

Searching for GSM network – GSM LED flashes once every second.

The tracker is attached to GSM network – GSM LED flashes once every three seconds.

GSM modem is turned off – GSM LED is OFF.

Indication of the battery charging

Battery charging – NAVIGATION / CHARGING LED flashes green and red simultaneously once a second.



When turning on the tracker for the first time it can take up to 26 seconds to start normal operation. In normal operation mode the NAVIGATION / CHARGING LED flashes green and the GSM LED flashes orange once every three seconds.

Drivers Installation

This section covers the installation procedure of the AutoGRAPH-Mobile tracker drivers.



The AutoGRAPH-Mobile drivers (AGUSBdriver) can be downloaded for free from the official web site of the manufacturer (www.tk-chel.ru). The drivers are compatible with Microsoft Windows XP, 7, Vista, 8, Server 2003, Server 2008 and Server 2012.

To install the device drivers onto a Microsoft Windows 7 OS:

1. Connect the tracker to your PC using USB AM – USB microB 5pin data cable. The system will automatically search for new equipment (Fig.1). For proper operation, it is sufficient to install driver for AutoGRAPH and AutoGRAPH CDC devices.
2. If the Internet connection is available, Windows 7 will automatically connect to the Windows Update website and install suitable driver for the tracker. If the Internet connection is not available, continue with the procedure outlined below.
3. Download the archived drivers folder from the official website of TechnoKom - AGUSBdriver.zip file and extract files to a temporary directory on a hard drive.
4. Launch the driver update wizard for new equipment (AutoGRAPH device) and select "Browse my computer for driver software" to search for drivers manually (Fig.2).

Fig.1.

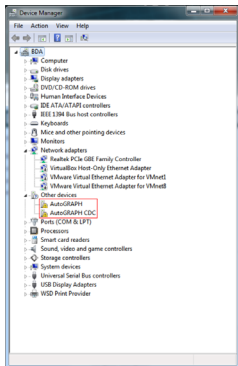
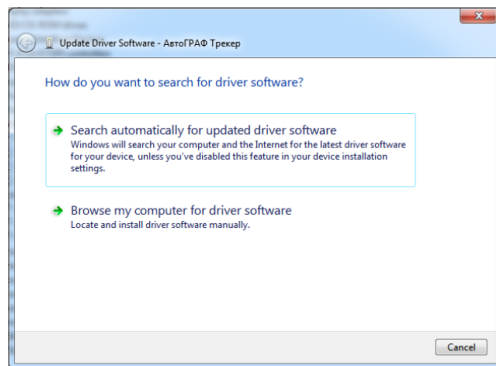

Fig.2.



5. Browse to the location where the drivers are saved (Fig.3).
6. Install the driver. When the driver is installed the system will automatically identify connected device (Fig.4).
7. Install drivers for the AutoGRAPH CDC device following the outlined instruction.

Fig.3.

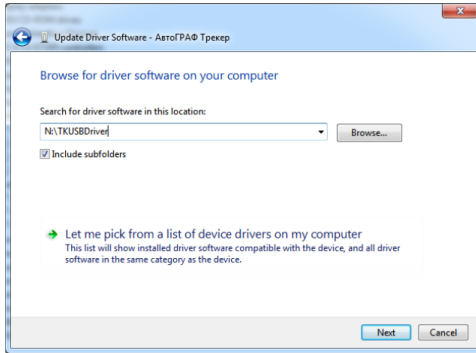
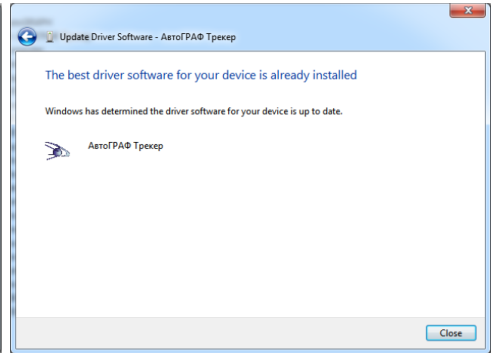

Fig.4.



8. Drivers for the AutoGRAPH-Mobile are successfully installed. The device is ready to operate with troubleshooting utilities, dispatch software and other applications.

Connection to PC

For configuration the tracker and reading the data, it is necessary to connect the AutoGRAPH-Mobile to a PC. Use USB AM – USB microB 5pin data cable to connect the device to a PC.

To connect the device to a PC:

- Turn on the tracker.
- Connect the data cable to mini USB connector of the tracker.
- Connect the other end of the cable to the PC.
- If the device drivers have been installed previously, the system will automatically identify the connected device.
- The tracker is now ready to operate with the MobileConf configuration program .

Care & Maintenance

Following simple instructions described below, you can maximize the tracker performance.

- Keep it away from extreme temperatures.
- Avoid excess moisture and exposure of chemical substances.
- Don't drop it and keep it safe.
- Use only batteries and chargers, approved by the manufacturer. Using incompatible batteries can damage the tracker.



USER MANUAL v. 2.4

TechnoKom Ltd.

Copyright © Chelyabinsk, 2015. All Rights Reserved.

www.tk-chel.ru

mail@tk-chel.ru